

Turbine flowmeters Series TM



- Suitable for liquids
- Possibility of installation in all flow directions
- Special design for high pressure available
- Excellent relationship flow range / flowmeter size
- Low pressure drop
- Flow rate: 0.3 ... 650 m³/h
- Accuracy: $\pm 0.5\%$ measured value
- Repeatability: $\pm 0.1\%$
- Connections:
 - EN 1092-1 DN15 ... DN150 flange
Other standards on request
 - BSP or NPT threaded connection
 - Sanitary couplings according to ISO 2852, SMS 1145,
DIN 11851, TRI-CLAMP®
- Materials:
 - Body: EN 1.4404 (AISI 316L)
 - Propeller: EN 1.4016 (AISI 430)
 - Shaft / Bearings: Tungsten carbide / Graphite
- Optional:
 - Flow rate indication, local or remote
 - Volume totalizer, local or remote
 - Electronic transmitter with 4-20 mA analog output. HART
protocol available on request
 - Volume preselector for batching processes
 - ATEX version. Exd protection



Working principle

One helicoidal rotor turns freely inside a cylindrical tube.

The working liquid pushes the rotor blades, making them turn at a flow speed which is proportional to the flow rate.

A pick-up coil mounted externally receives the propeller turns and generates an electrical signal which, once treated by the different electronic converters, provides:

- Flow rate indication
- Total or partial volume
- Digital and analog outputs (mA, Hz and V)

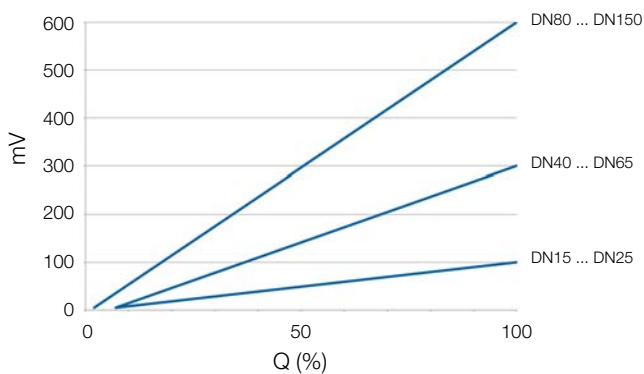
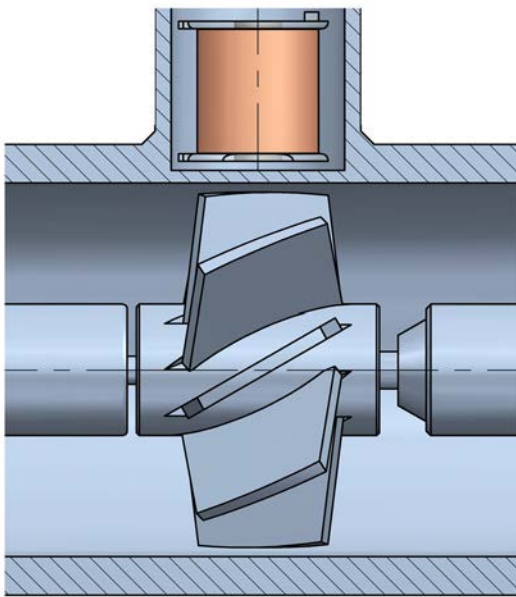

Approximate output voltage (without amplifier), depending on flow rate

Applications

- Chemical and petrochemical industry
- Tank filling and batching applications
- Measurement of steam condensates in boilers
- Burners, measurement of fuel consumption

Technical data

- **Accuracy:** $\pm 0.5\%$ measured value
- **Repeatability:** $\pm 0.1\%$
- **Response time:** 10 ms
- **Output signal:** according to graph
- **Scale range:** 10:1
- **Fluid temperature:** $-50^{\circ}\text{C} \dots +170^{\circ}\text{C}$
- **Working pressure:**
 - DN15 ... DN50: PN40
 - DN65 ... DN150: PN16

Others on request

- **Connections:**
 - EN 1092-1 DN15 ... DN150 flange
Other flange standards on request
 - BSP or NPT threaded connections
 - Sanitary couplings according to ISO 2852, SMS 1145, DIN 11851, TRI-CLAMP®
- **Mounting in horizontal or vertical pipe, and installation in all flow directions**

Electronic converters and options

- **CP ... CH420:** flow rate indication, volume totalizer and 4-20 mA output, 2-wire system. Compact or remote mounted. HART protocol with model CH420
- **CIP:** volume totalizer. Battery powered. Compact or remote mounted
- **CIP II:** non-resettable volume totalizer, resettable partial volume totalizer. Battery powered. Compact or remote mounted
- **MC01:** flow rate indication, volume totalizer and volume preselector with relay output for batching applications. 4-20 mA analog output as an option, 4-wire system. Panel mounted
- **MT02:** volume totalizer, partial volume totalizer and volume preselector with relay output for batching applications. Panel mounted
- **DFD2:** frequency divider. DIN rail mounted
- **APT44:** pulse amplifier. DIN rail mounted
- **Options:**
 - Special connector for other displays (please consult)
 - Exd version for hazardous environments

Mounting

For both horizontal or vertical pipes and installation in all flow directions (horizontal pipe is recommended for DN125 and DN150). A straight pipe run without any disturbing element (elbows, valves, filters, etc) of 10 x DN before and 5 x DN after the turbine flowmeter is required. The upstream distance can be reduced to 5 x DN if a straightener is installed.

In order to avoid that small particles can damage the turbine propeller it is mandatory to install a filter before the flowmeter with a mesh size of 1 mm up to DN100 and 3 mm for bigger sizes.

In those processes where air or gases, liquid evaporation, etc. might be present, an air/steam separator must be installed before the turbine flowmeter, in order to avoid measurement errors.

It is essential to avoid cavitations inside the turbine flowmeter. In order to do this, on the outlet of the flowmeter the pressure must be at least twice the pressure drop of the flowmeter, plus 1.25 times the vapour pressure of the liquid.

The wiring between the turbine flowmeter and the associated electronic converters must be made so that no mains or power supply cables are placed around the devices, in order to avoid picking up interferences that might affect the reading.

For an optimal signal transmission the following is recommended:

- up to 30 m, 2-wire shielded cable
- up to 100 m, installation of pulse amplifier model APTM44
- up to 3000 m, installation of Hz/mA converter model CP ... CH420L

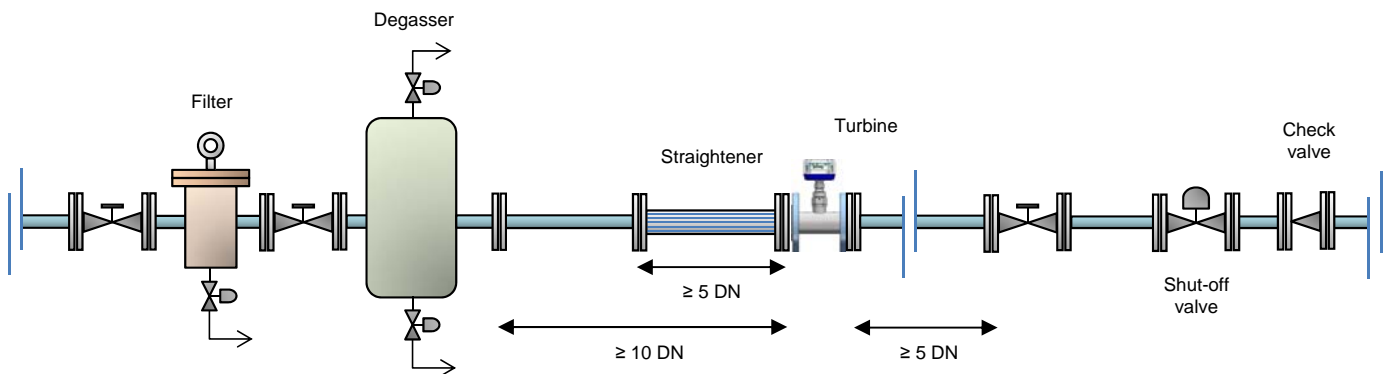

Materials

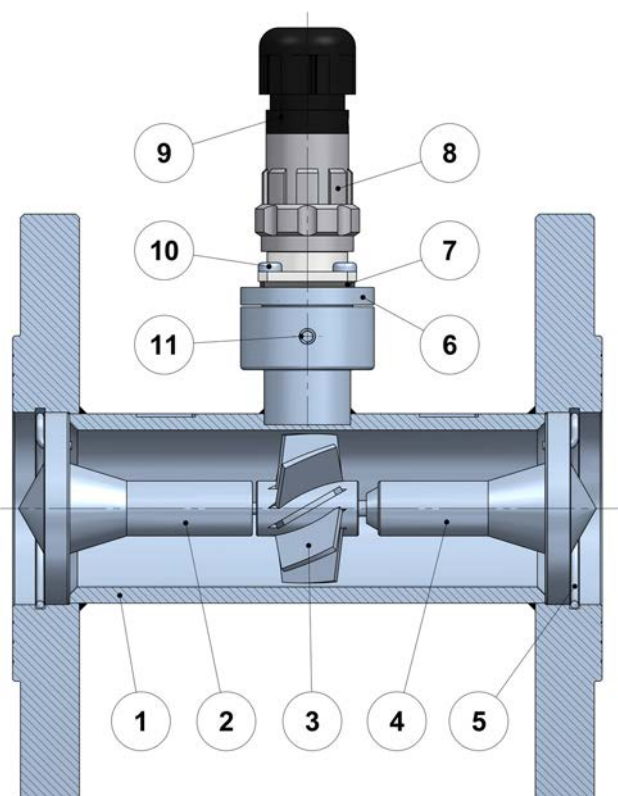

N°	Description	Materials
1	Measuring body	EN 1.4404
2	Inlet deflector	EN 1.4404 + WC
3	Propeller	EN 1.4016 + Graphite + WC
4	Outlet deflector	EN 1.4404 + WC
5	Circlip	EN 1.4401
6	Coil support	EN 1.4305
7	Gasket	NBR
8	Connector	Anodized aluminium
9	Packing gland	Plastic
10	Screw DIN 7985 M3 x 8	EN 1.4301
11	Screw DIN 913 M4 x 8	EN 1.4301

Note:

EN 1.4404	AISI 316L
EN 1.4016	AISI 430
EN 1.4401	AISI 316
EN 1.4301	AISI 304
EN 1.4305	AISI 303
WC	Tungsten carbide

Dimensions

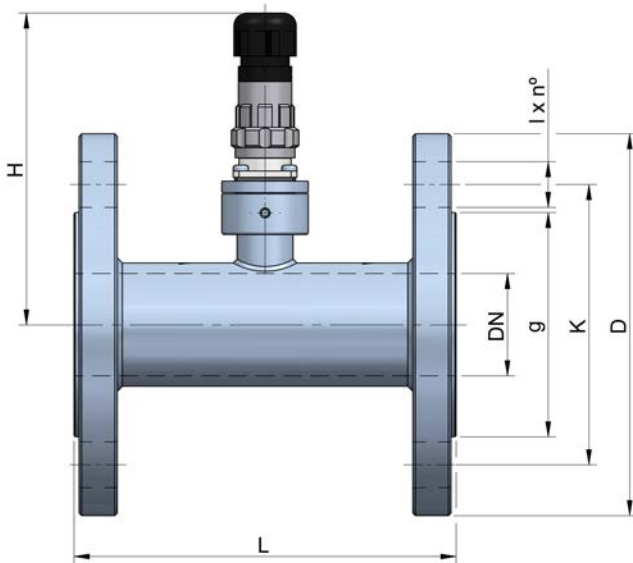

DN	PN	D	K	g	I x n°	L	H	Weight (kg)
15	40	95	65	45	14 x 4	100	115	2.0
20	40	105	75	58	14 x 4	100	115	2.5
25	40	115	85	68	14 x 4	130	120	3.5
40	40	150	110	88	18 x 4	150	125	5.0
50	40	165	125	102	18 x 4	150	130	7.0
65	16	185	145	122	18 x 8	160	140	10.0
80	16	200	160	138	18 x 8	160	145	12.0
100	16	220	180	158	18 x 8	250	155	17.0
125	16	250	210	188	18 x 8	280	170	21.0
150	16	285	240	212	22 x 8	300	180	27.0

All dimensions in mm

Flow ranges

DN	Flow scales m ³ /h water	Max. intermittent m ³ /h water	pulses / litre approx.	ΔP mbar at Qmax
15	0.3-3	4	730	750
20	0.6-6	8	500	750
25	0.9-13.6	16	220	700
40	1.9-30	40	60	560
50	5-50	60	20	280
65	9-90	115	10	240
80	15-150	180	5	310
100	28-280	340	3	450
125	45-450	560	1.5	240
150	65-650	820	0.8	250

The TM turbine flowmeters are calibrated with water (density 1 kg/l and viscosity 1 mPa·s).

It is recommended that minimum flow rate is at least 10% of the flow scale in order to obtain the highest accuracy.

The measurement errors can be corrected in the different associated electronic converters by means of the adjustment of the k factor (pulses / volume unit), obtaining a maximum accuracy.

A change in viscosity can modify the k factor. The measurement error due to these changes in viscosity is approximately indicated in the curves on next page.

In general, changes in density and viscosity affect the turbine flowmeters. The higher the density and the viscosity are, the lower the initial flow rate required is so that the propeller starts turning, that is, the lower the beginning of the scale is. In the same way, for lower values of density and viscosity, the beginning of the scale is higher.

The TM turbine flowmeters are suitable for liquids with viscosities up to 100 mPa·s, although it is very important that liquid viscosity remains unchanged during operation in order to avoid measurement errors.



Flow rate and pressure drop (ΔP) curves

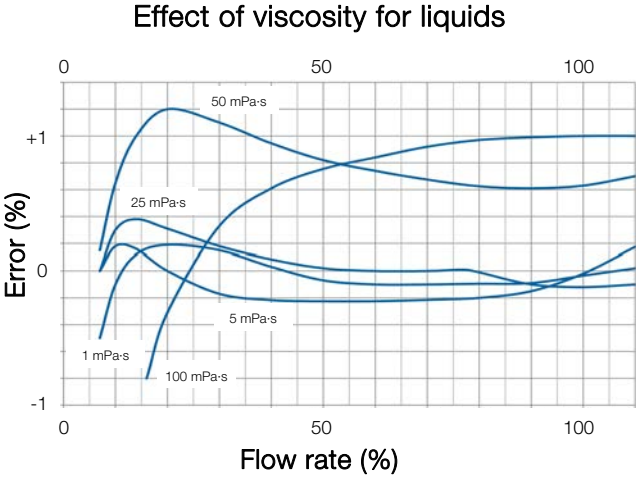
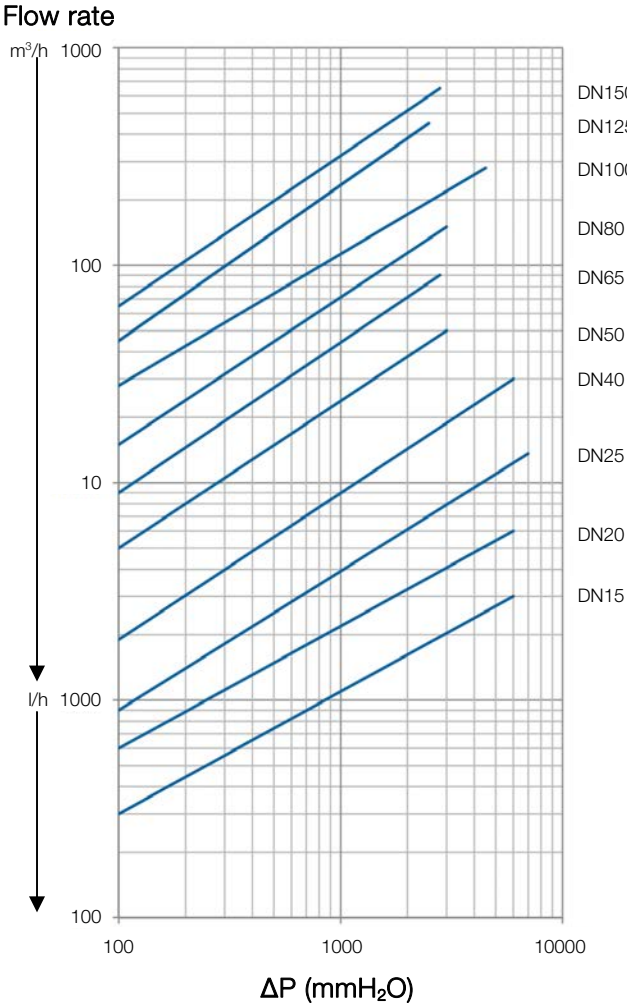

Variations of pressure drop due to the effect of density and viscosity

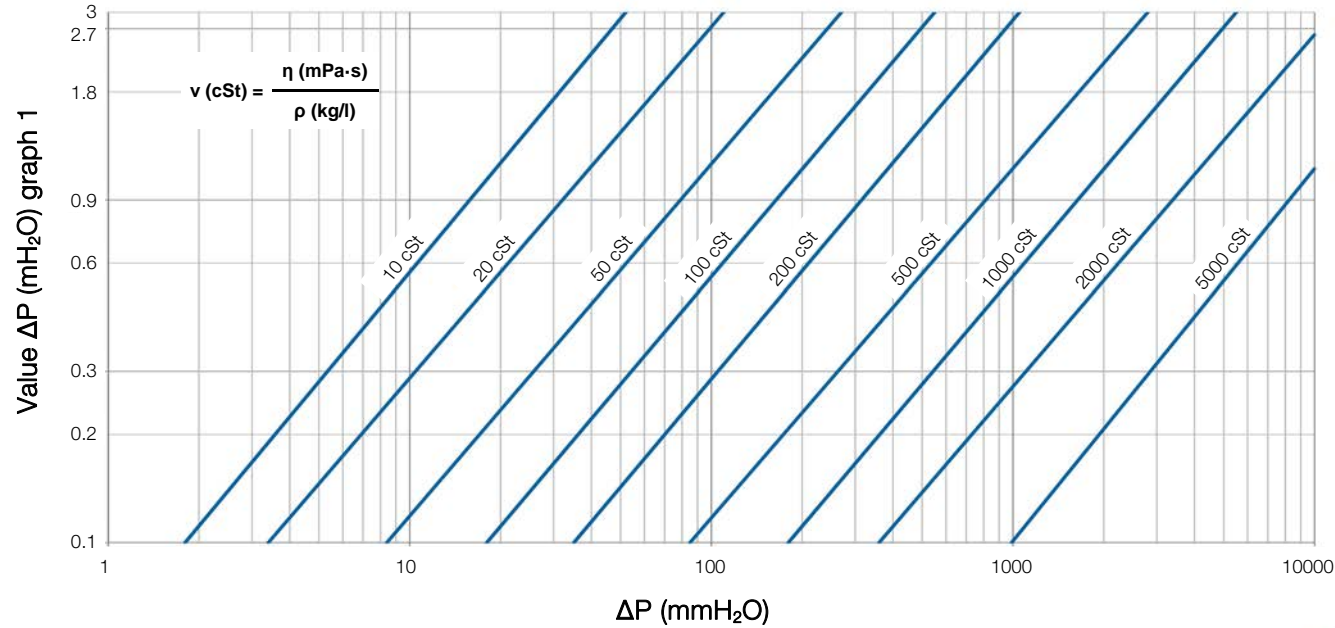

Electronic converters

Model APTM44

- Pulse amplifier
- DIN 46277 rail mounted
- Adaptable to pulse and mV emitters
- Does not need adjustment on site
- Allows the connection between a turbine flowmeter and a PLC or other devices that do not admit a pick-up type input
- Power supply: 24, 110, 220, 240 VAC 50 / 60 Hz, 24 VDC
- Power consumption: 1 VA
- Output TTL (0-5 V)
- Pulse width: 0.1 ms
- Maximum input frequency: up to 1500 pulses / s
- Ingress protection: IP40 (terminals IP20)
- Ambient temperature: 0°C ... +50°C
- Recommended for signal transmission from 30 m and up to 100 m

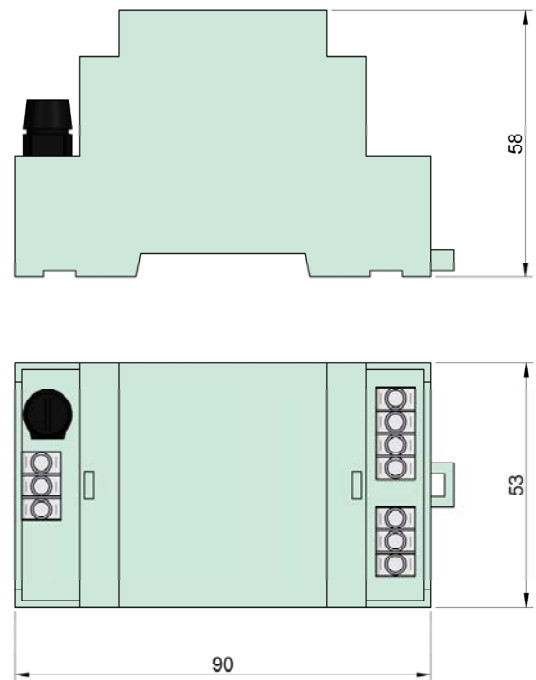

Model CP ... CH420



- 4-20 mA transmitter
- System:
 - Compact (CP ... CH420L)
 - Remote in DIN rail (CP ... CH420R)
 - Remote in panel (CP ... CH420P)
- Electronics mounted in a housing with aluminium base and polycarbonate (UV resistant) cover (CP ... CH420L)
- Power supply:
 - 2-wire, loop powered
 - Nominal voltage: 8 ... 36 VDC
 - Power consumption: ≤20 mA
- Totalizer:
 - N° of digits: 7
 - Size of digit: 8 mm
 - Reset: by means of keyboard
- Flow rate indication:
 - N° of digits: 5
 - Size of digit: 5 mm
- Programmable beginning and end of scale
- Several selectable flow rate indication and totalizer units
- Programmable pulse / litre factor
- Ingress protection:
 - IP65 for CP ... CH420L
 - IP30 for CP ... CH420R
 - Front IP50 (IP65 on request) and back IP30 for CP ... CH420P
- Ambient temperature: 0°C ... +60°C
- HART protocol available with models CH420L ... R ... P
- Allows the transmission of the 4-20 mA signal up to 3000 m



CP ... CH420L



CP ... CH420P



CP ... CH420R

Turbine flowmeters

Series TM

Dimensions TM + CIP ... CIP II / CP ... CH420L

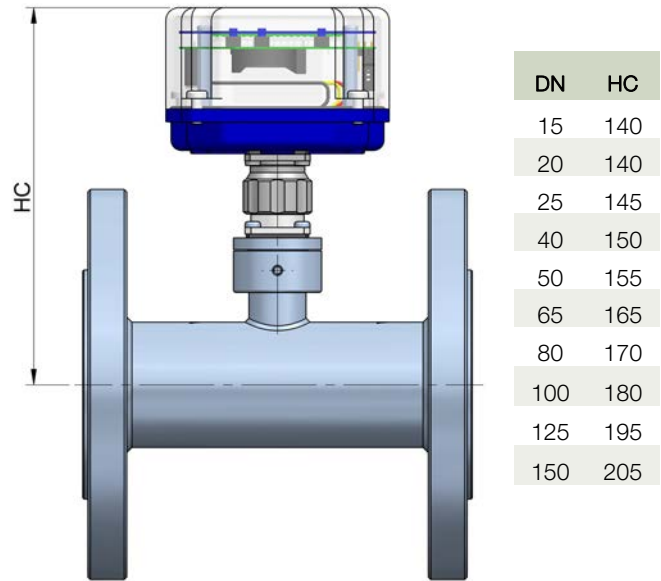

Model CIP ... CIP II

- Volume totalizer:
 - Model CIP: resettable totalizer
 - Model CIP II: non-resettable totalizer and resettable partial totalizer
- Compact or remote system
- Electronics mounted in a housing with aluminium base and polycarbonate (UV resistant) cover
- Battery powered (CR-2450):
 - Nominal voltage: 3 V
 - Load: 560 mAh
 - Power consumption: 8 μ A
- Totalizer:
 - N° of digits: 7
 - Size of digit: 8 mm
 - Reset: by means of key or magnet (non-resettable for CIP II)
- Partial totalizer (only available for CIP II):
 - N° of digits: 5
 - Size of digit: 5 mm
 - Reset: by means of key or magnet
- Battery life: 5 years approx.
- Programmable pulse / litre factor
- Ingress protection: IP65
- Ambient temperature: 0°C ... +50°C



Model DFD2

- Frequency divider
- Fully programmable by the user
- DIN 46277 rail mounted
- Acts as an interface between the series TM turbine flowmeters and systems with frequency limited pulse input, such as some PLCs or mechanical counters.
- Power supply: 24, 110, 220, 240 VAC 50 / 60 Hz, 24 VDC
- Power consumption: 1 VA
- Outputs:
 - TTL (0-5 V)
 - Optoisolated max. 30 V 50 mA
- Special inputs TTL or NAMUR
- Ingress protection: IP40 (terminals IP20)
- Ambient temperature: 0°C ... +50°C

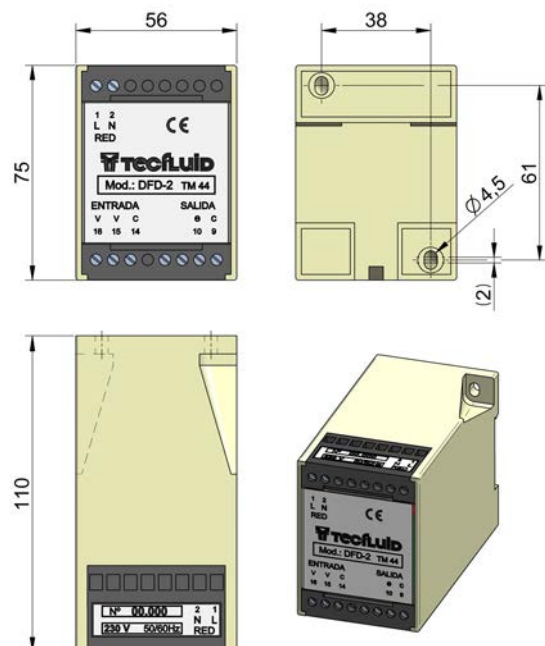

Model MC01

- Electronic converter for flow rate indication, volume totalizer, partial volume totalizer and preselector with relay output for batching
- Fully programmable by the user
- Panel mounted
- Power supply: 24, 110, 220, 240 VAC 50 / 60 Hz
12, 24 VDC
- 2-line LCD display with 16 characters (5 mm height)
- 7 digits totalizer, partial totalizer and volume preselector
- Relay output for batching
- Flow rate indicator in l/h y m³/h
- Dimensions 96 x 96 mm DIN 43700
- Ingress protection: IP50 front, IP30 back
- Ambient temperature: -10°C ... +50°C

Options

- 0 ... 4-20 mA analog input or output, 4-wire system
- Reset and batching start by means of remote button
- Plastic front protection with key and silicone cover, for IP65 rating



Model MT02

- Electronic converter for volume preselection and totalization
- Fully programmable by the user
- Panel mounted
- Power supply: 24, 110, 220, 240 VAC 50 / 60 Hz
12, 24 VDC
- 7 digits LED display for total and partial volume and preselection + 1 digit for operation mode
- Relay output for batching
- Dimensions 96 x 96 mm DIN 43700
- Ingress protection: IP50 front, IP30 back
- Ambient temperature: -10°C ... +50°C

Options

- Reset and batching start by means of remote button
- Plastic front protection with key and silicone cover, for IP65 rating
- Version with double relay for fast approximation and slow final adjustment for batching processes, model MT02/2



Dimensions converters MC01 / MT02

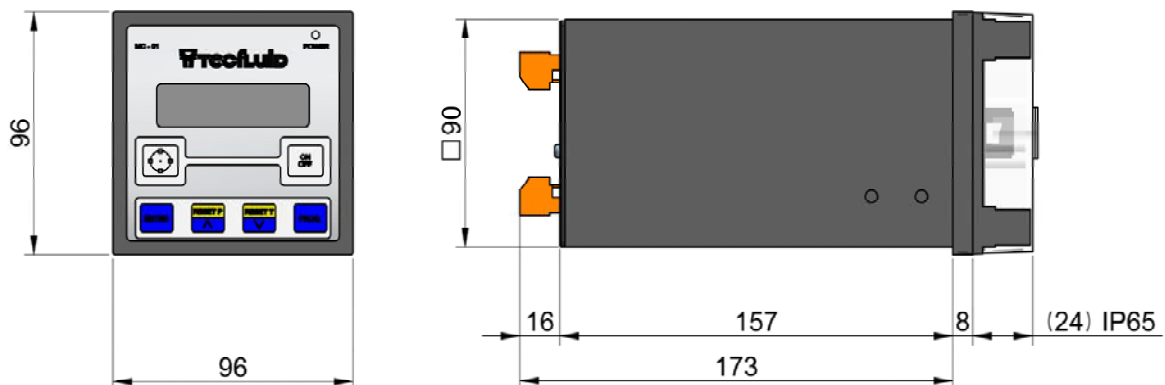

Turbine flowmeters

Series TM

ATEX version

The TM turbine flowmeter is suitable for its installation in ATEX hazardous area, that is, in those zones where a potentially explosive atmosphere can be generated. There are two types of protection available: Exi intrinsically safe or Exd ExProof.

Exia protection

This device is considered as "simple apparatus" according to EN 60079-11 standard clause 5.7, since it does not contain its own source of ignition.

Pick-up coil technical data:

- $L_i \leq 700$ mH
- $C_i \leq 30$ pF
- Internal resistance > 1700 Ohm
- $U_i \leq 3$ V

According to these data, the turbine flowmeter can be installed in hazardous area when an appropriate zener barrier (please consult) is installed between the hazardous and the safe area. The electronic converters, however, must always be installed in safe area.



Exd housing model ADF60V with CIP II display

Exd protection

These devices conform the 94/9/CE directive (Devices and protection systems for use in potentially explosive atmospheres) as indicated in the CE certificate type LOM 14ATEX and its corresponding marking.

The instrument belongs to group II, therefore it is intended for use in places where there is a risk of generation of an explosive atmosphere, except in mining.

Being category 2GD it can be used in an environment where it is probable to generate an explosive atmosphere due to air and gases mixtures, vapours, mist and dust as well.

Three different types of Exd housings are available:

- Model ADF30: blind housing with reduced dimensions
- Model ADF60V: housing with window, can include the CIP ... CIP II or CP ... CH420L converters
- Model ADF60: same as ADF60V but blind housing

Exd version technical data:

- Ambient temperature: $-20^{\circ}\text{C} \dots +60^{\circ}\text{C}$
- Electrical wiring inside the Exd housing
- On request ATEX packing glands for standard or shielded cable
- Associated electronics, for models:
 - CIP ... CIP II: totalizer battery powered
 - CP ... CH420: transmitter 2-wire system with flow rate indication, volume totalizer and 4-20 mA output. HART protocol optional
- ATEX certificate Ex d IIC T6 Gb / Ex tb IIIC T85°C Db

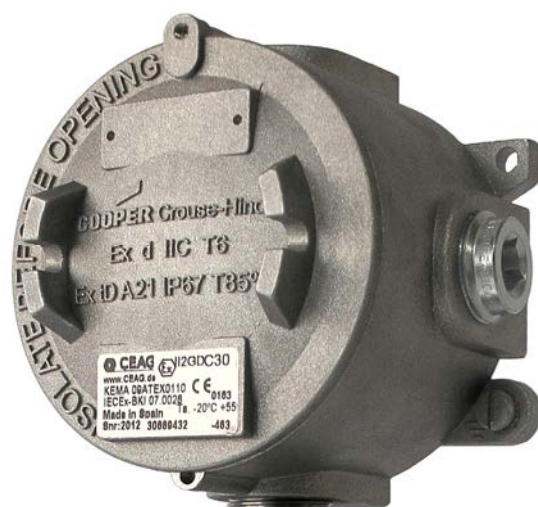

Exd housing model ADF30

Tecfluid
82, Avenue du Château
Z.I. du Vert Galant - ST OUEN L'AUMONE
B.P. 27709
95046 CERGY PONTOISE CEDEX - FRANCE
Tel : 00 33 1 34 64 38 00
Fax : 00 33 1 30 37 96 86
info@tecfluid.fr
www.tecfluid.fr